

# GATERON

## Product Specification



GATERON Product Name:

Hot swap 2.0

GATERON Item No.:

KS-2P02B01-01-a

1. This Product Specification is considered as the technical agreement on product between the receiving customer and GATERON. Any information on the Product Catalogue which is in conflict with or different from the corresponding information of this document is considered as invalid.
2. If customer issue purchase orders without confirmation by signature of this specification after receipt, such confirmation will be considered as granted upon receipt of the first purchase order.
3. If there is no order or no request for new specification after 1 year upon this specification is issued, the specification will be regarded as invalid.

### 1. General Characteristics:

1.1 Application	This specification is applied to the mechanical shaft connection socket for general applications.
1.2 Operating Temperature Range	-40°C to +80°C
1.3 Operating Relative Humidity Range	≅ 85% RH, +40°C
1.4 Test Conditions	Unless otherwise specified, the atmospheric conditions for making measurements and tests are as follows: Ambient Temperature: 5-35°C Air Pressure: 86-106 Kpa Relative Humidity: 45-85% RH

### 2. Appearance, Structure and Dimensions:

2.1 Appearance	The connector shall have good finishing, and no rust, crack or plating defects.
2.2 Structure and Dimensions	Refer to individual product drawing
2.3 Markings	Refer to individual product drawing.

### 3. Protection against ingress of dust and water

Protection against ingress of dust and water:	IP00
---	------

4. Electrical Characteristics:

Item	Criteria	Test Method	
4.1	Insulation Resistance	100MΩ Min.	100V DC voltage is applied between each pair of terminals for 60 ± 5 Sec.
4.2	Contact resistance	100 mΩ Max	Measured by contact-to- contact method at 1mA Max,5VDC,Any equipment with error not more than 5% can be used Resistance after test is the average of 4 successive measurements.
4.3	Dielectric Voltage	No dielectric breakdown shall occur	100V(50-60HZ,cut –off current 2mA )alternate current load is applied between open terminals and between terminals and the metal frame or between metal parts, for 60 ± 5 Sec.

5. Mechanical Characteristics:

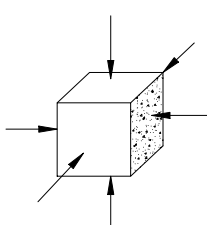
Item	Criteria	Test Method	
5.1	Push force	Push force:3kgf Max	At 16in/minute actuation speed.
5.2	Vibration		(1)(Vibration frequency range) = <u>10-55</u> Hz (2)(Total amplitude) = <u>1.5mm</u> (3)(Sweep ratio): <u>10-55-10Hz</u> 1(Approx. 1 min.) (4) : (Method of changing the sweep vibr frequency:logarithmic or linear) (5): ( Direction of vibration: Three perpendicular directions including actuating direction.) (6): Duration : 2 hours / direction (6 hours in total)
5.3	Shock	After test: - 4.1~4.3 - Electrical characteristics of items 4.1~4.3 shall be satisfied. - 5.1 - Mechanical characteristics of items 5.1 shall be satisfied.	(Connector shall be measured after following test:) (1) : ( Mounting Method: Normal ) (2) (Acceleration): <u>784 m/s<sup>2</sup></u> (80G) (3) ( Duration ) : <u>11ms</u> (4) : (Test Direction : 6 directions) (5) : Number of shocks : 3 times per direction (18 times in total)
			
5.4	Soldering resistance	No damage ( electrical and mechanical)	SMT molten tin temperature≤260±5°C for 5±1 seconds
5.5	Solder-Ability	More than 90% of immersed part shall be covered with solder.	Solder paste for SMT solder temperature : ≤260± 5°C soldering time :2±0.5 sec

6. Durability Characteristics:

Item	Criteria	Test Method	
6.1	Mechanical Endurance	After test: Contact resistance: 200mΩ Max Items 5.1 shall be satisfied.	50000 cycles of operation shall be performed continuously at a rate of 20 cycles per minute with Key Switch.

7. Weather Proof Characteristics:

X	Item	Criteria	Test Method												
7.1	Cold Proof	After test: : Contact resistance: 200mΩ Max Electrical characteristics of items 4.1, 4.3, 5.1~5.3 shall be satisfied.	After testing at $-40\pm 2^{\circ}\text{C}$ for 96 hours, the connector can stay under normal temperature and humidity conditions for 1 hours, and measurement shall be made within 1 hour after that. Water drops shall be eliminated.												
7.2	Hot Proof		After testing at $80\pm 2^{\circ}\text{C}$ for 96 hours, the connector can stay under normal temperature and humidity conditions for 1 hours and measurement shall be made within 1 hour after that.												
7.3	Temperature Cycling		<p>After 20 cycles of following conditions, the connector can stay under normal temperature and humidity conditions for 1 hours, and measurement shall be made within 1 hour after that. Water drops shall be eliminated.</p> <table border="1" data-bbox="871 949 1461 1196"> <thead> <tr> <th></th> <th>Temperature</th> <th>Duration of test</th> </tr> </thead> <tbody> <tr> <td rowspan="4">1 1 Cycle</td> <td><math>20\pm 5^{\circ}\text{C}</math></td> <td>1h</td> </tr> <tr> <td><math>-40\pm 2^{\circ}\text{C}</math></td> <td>1h</td> </tr> <tr> <td><math>20\pm 5^{\circ}\text{C}</math></td> <td>1h</td> </tr> <tr> <td><math>80\pm 5^{\circ}\text{C}</math></td> <td>1h</td> </tr> </tbody> </table>		Temperature	Duration of test	1 1 Cycle	$20\pm 5^{\circ}\text{C}$	1h	$-40\pm 2^{\circ}\text{C}$	1h	$20\pm 5^{\circ}\text{C}$	1h	$80\pm 5^{\circ}\text{C}$	1h
	Temperature	Duration of test													
1 1 Cycle	$20\pm 5^{\circ}\text{C}$	1h													
	$-40\pm 2^{\circ}\text{C}$	1h													
	$20\pm 5^{\circ}\text{C}$	1h													
	$80\pm 5^{\circ}\text{C}$	1h													
7.4	Moisture Resistance		After testing at $40\pm 2^{\circ}\text{C}$ , 90-95% RH for 96 hours, the connector can stay under normal temperature and humidity conditions for 1 hours, and measurement shall be made within 1 hour after that. Water drops shall be eliminated.												
7.5	Salt Mist	Contact resistance 200mΩ max No. 4.1, 4.3, 5.1, 5.2 shall be satisfied	<p>The connector shall be checked after following test:</p> <ol style="list-style-type: none"> <li>1. Temperature: <math>35\pm 2^{\circ}\text{C}</math></li> <li>2. Salt solution: <math>5\pm 1\%</math> (Solids by mass)</li> <li>3. Duration: 24 hours,</li> <li>4. After immersing, salt deposit shall be removed by running water.</li> </ol>												

## 8. Mounting Options:

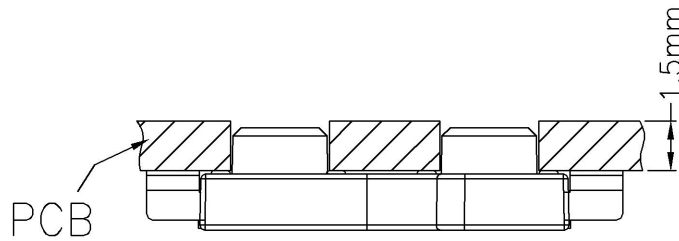

## 9. Circuit Board Layouts:

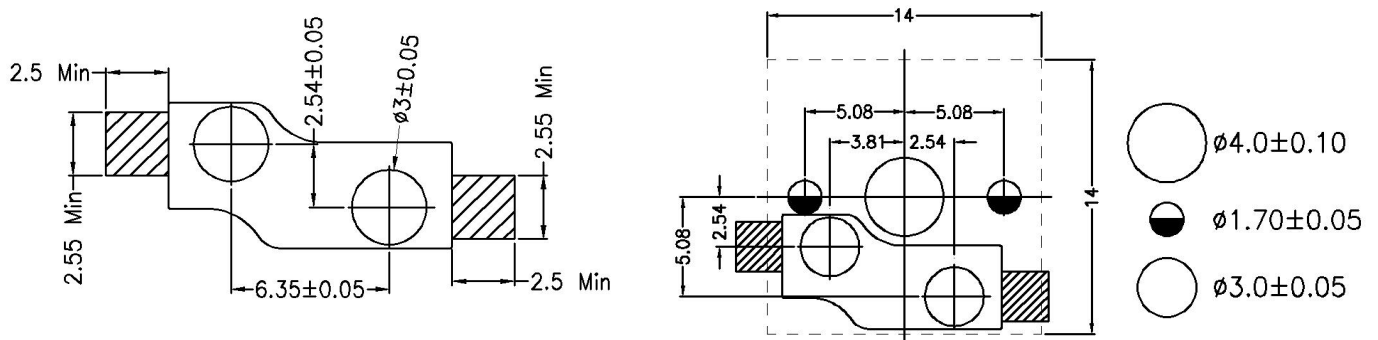

## 10. BOM:

No.	Parts Name	Quantity	Material and Specifications	Prevent fire grade	Remarks
1	Terminal	2	Copper Alloy		
2	Base	1	Macromolecule polymer		Black

### Precautions for use:

#### 1. General:

2. The product is used mainly in electronic devices such as automotive devices, visual devices, home electrical appliances, information devices and communication settings. If the products is intended to be used for other endurance equipments requiring higher safety and reliability such as life support system, space and aviation devices, disaster and safety system, it' s necessary to make verification of conformity or contact us for the details before using.

#### 2. Soldering and assembly:

- (1) The soldering conditions should be confirmed according to the actual production environment.
- (2) Don' t try to clean the connector with a solvent or similar substance after the soldering process.
- (3) Don' t operate the connector if it still has heat after soldering.
- (4) The connector might be damaged if using the water-soluble flux, so make sure not to use such kind of flux.

#### 3. Assembly structure and Mechanical design:

(1) The dimensions for the holes and the pattern on PCB should refer to the recommended dimensions on the engineering drawing.

(2) The connector might be broken if there is stress stronger than the specified is given on it. Take special care not to stress the connector beyond its specification.

(3) If the connector is being used together other products, please confirm the compatibility of the specification, laws and regulations. Please also confirm the compatibility of connector to be installed in the systems, machines and devices used by customer. If you want to change the operating conditions of the connector, please consult with us in advance.

#### 4. Operating Environment

(1) If the product is always used near sulfurate hot spring where sulfide gas is generated or in a place where exhaust gas from automobiles exists, it's necessary to pay more attention because the connector performance may be affected.

(2) If the below parts or materials are used in the module where the connector is installed, directions below should be followed:

A. For parts, rubber materials, adhesive agents, packing material and grease used for the mechanical part of the device, don't use any material that may generate gas of sulfurization or oxidization.

B. If silicon rubber, grease, adhesive agents and oil are used, choose the material that will not generate low molecular siloxane gas, because the low molecular siloxane gas may form silicon dioxide coat on the connector contact part, resulting of failing contact.

(3) Don't use the connector in the environment with high humidity or other bedewing possibility, as it may cause leaking among the terminals.

(4) The effect caused by outer immersed dust: Because the connector was designed without dust-proof structure, it may have failing contact due to the immersed dust from the outer environment. When using the connector, it's necessary to take dust-proof actions. Examples of immersed dust, which should be prevented during the operation:

A. The scraps being generated during PCB processing, or other waste from the protective material for PCB such as newspaper, foam, polystyrene materials, may immerse inside the connector.

B. The flux or solder powder being generated when stacking the PCB may immerse inside the connector.

5. Storage Method:

(1) In order to protect the connector performance and the soldering conditions, it should keep the connector under the following conditions:

A. Temperature of -20°C to +70°C, with humidity lower than 85%RH;

B. Avoid storing in the environment containing corrosive gas;

C. After purchasing, the storage period should not exceed 6 months.

D. Avoid keeping it in the location with direct sunlight.

(2) Store using the standard packing without exerting force.

(3) The standard storage period is 3 months, with maximum up to 6 months, preferably to be used as soon as possible. After opening the package, you should put the remaining switches in a plastic bag to prevent from damp and corrosive gas.

6. Others: Please take good care to comply with the following guidelines:

(1) , The prohibited practices where there is fire and fume:

A , It might catch fire if the rating exceeds the specifications. Never use the connector beyond the rating.

B , If the rating may exceed due to some abuse or abnormal usage, please take protective measures such as protective circuit to shut down the circuit.

(2) Precautions to the products requiring special safety:

A , Though we are confident in connector quality, we can't deny the possibility that there could be failure due to inferior performance, short or open circuit. Therefore, when designing the product requiring special safety, please verify in advance what effects would show on your product in case the connector alone may fail.

B , Prepare the system with protective circuit and protective devices for safety purposes.

C , Prepare safety standby circuit to preclude the whole system failure that may result from specific failure.

This specification issued by:

Company: Huizhou GATERON Electronic Technology Co., Ltd.

Address: No. 1, Songbei Road, China - Korea (Huizhou) Industrial Park, Zhongkai High Tech Zone, Huizhou City, Guangdong Province, China, 516000

Web: [www.gateron.com](http://www.gateron.com)

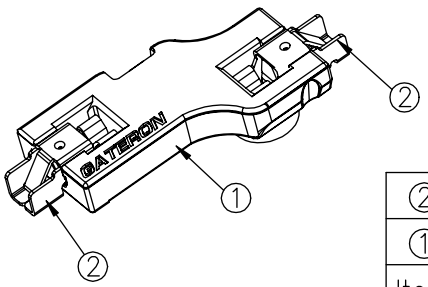
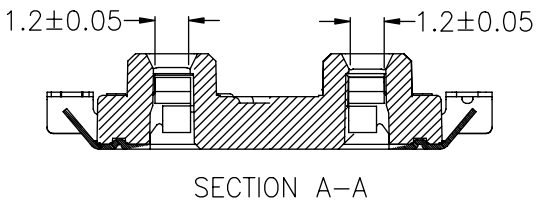
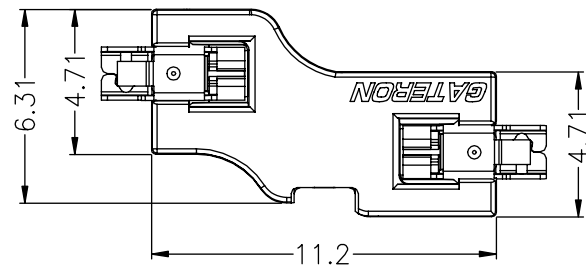
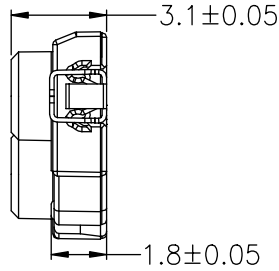
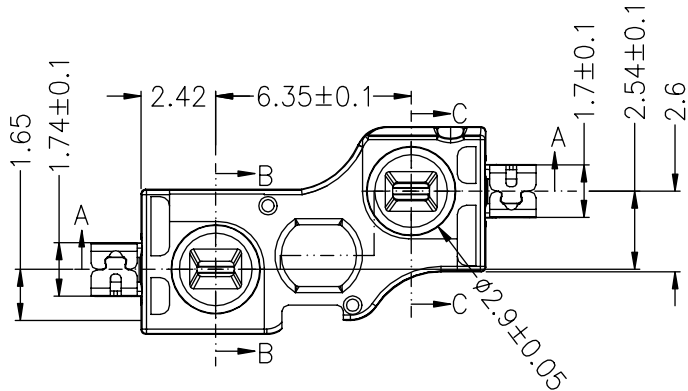
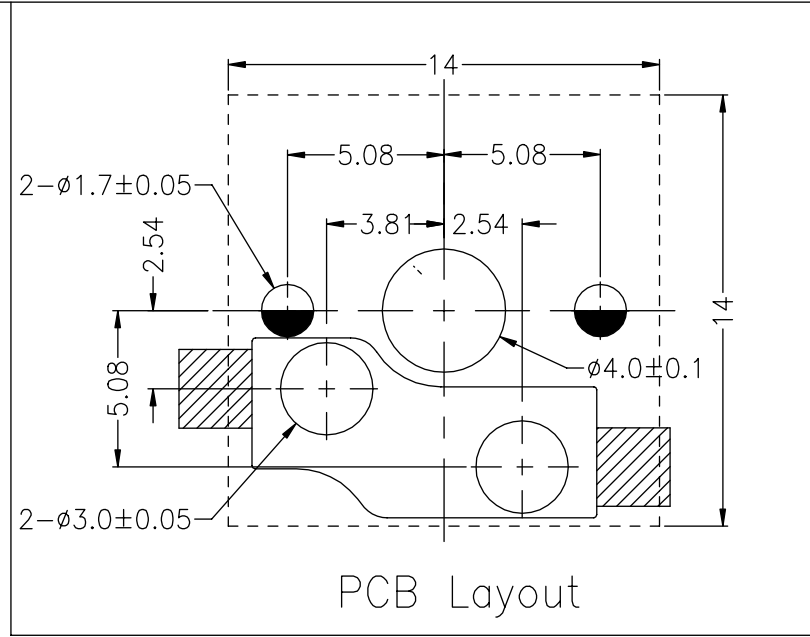
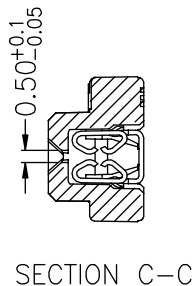
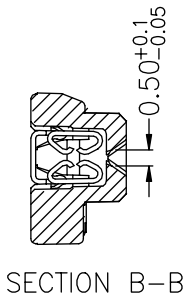
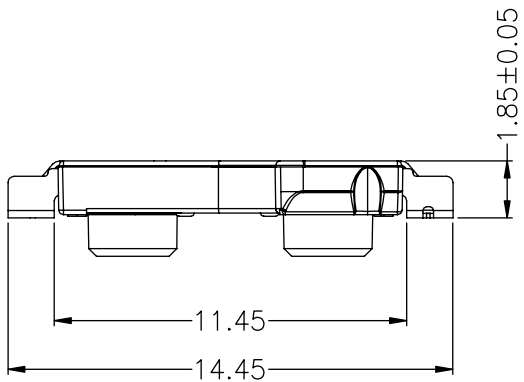

②	Terminal	2	Cu Alloy	Gold-plating	
①	Base	1	Macromolecule polymer	Black	
Item	Part name	QTY.	Material	Finishing	Remark

Specification:

1. Rating:

Voltage: 12VAC/DC Max. 2VDC Min;

Current: 10mA Max, 10μA Min;

2. Contact Resistance: 100mΩ Max;

3. Insulation Resistance: 100MΩ Min at 100VDC;

4. Withstand Voltage: AC100V(50~60Hz) for 1 minute;

5. Push force: 3.0Kgf Max;

6. Operation Life: 50000 cycles.

Four states of delivery

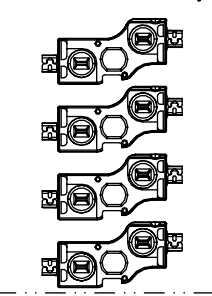

REV.	DATE	MODIFICATION							PRIOR VERSION
Title/Proj		Mechanical shaft connection socket(2.0)			Tolerance Unless Otherwise Specified				
Part No	KS-2P02B01-01-a	Version	2	~3	>3~10	>10~30	>30~80	>80~180	Angle
Drawing No	KS-2P02B01-01-a	Scale	4:1	±0.2	±0.3	±0.4	±0.6	±0.8	±3°
Drafted by	WuFurong	Date	2023-10-12	Unit: mm		Size: A4			
Checked by	Fu Dong	Date	2023-10-12	THIRD ANGLE		 <b>GATERON</b> GATERON Electronic Technology Co.,Ltd			
Approved by	He Shiying	Date	2023-10-12						