

GATERON

Product Specification



GATERON Product Name:

KS-57 Holder Module (Low Profile Plate Mounted Stabilizer 6.25U)

GATERON Item No.:

KS-57B623T

1. This Product Specification is considered as the technical agreement on product between the receiving customer and GATERON. Any information on the Product Catalogue which is in conflict with or different from the corresponding information of this document is considered as invalid.
2. If customer issue purchase orders without confirmation by signature of this specification after receipt, such confirmation will be considered as granted upon receipt of the first purchase order.
3. If there is no order or no request for new specification after 1 year upon this specification is issued, the specification will be regarded as invalid.

1. General Characteristics:

1.1 Application	This specification is applied to the Plate-mount Stab for general applications.
1.2 Operating Temperature Range	-25 to +80
1.3 Operating Relative Humidity Range	85% RH, +40
1.4 Test Conditions	Unless otherwise specified, the atmospheric conditions for making measurements and tests are as follows: Ambient Temperature: 5-35 Air Pressure: 86-106 Kpa Relative Humidity: 45-85% RH

2. Appearance, Structure and Dimensions:

2.1 Appearance	The switch shall have good finishing, and no rust, crack or plating defects.
2.2 Structure and Dimensions	Refer to individual product drawing

3. Weather Proof Characteristics:

Item	Criteria	Test Method
3.1 Cold Proof	After test: Characteristics of items 2.1 ~ 2.2 shall be satisfied.	After testing at -25 ± 2 for 96 hours, the switch can stay under normal temperature and humidity conditions for 1 hours, and measurement shall be made within 1 hour after that. Water drops shall be eliminated.
3.2 Hot Proof		After testing at 80 ± 2 for 96 hours, the switch can stay under normal temperature and humidity conditions for 1 hours and measurement shall be made within 1 hour after that.
3.3 Moisture Resistance		After testing at 40 ± 2 , 90-95% RH for 96 hours, the switch can stay under normal temperature and humidity conditions for 1 hours, and measurement shall be made within 1 hour after that. Water drops shall be eliminated.

4. Mounting Options:

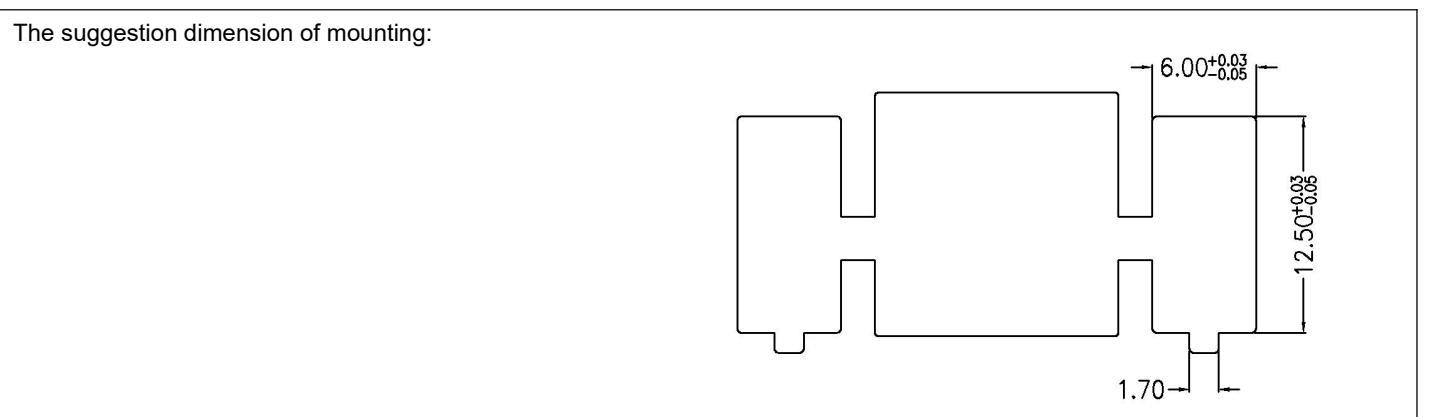

5. BOM:

No.	Parts Name	Quantity	Material and Specifications	Prevent fire grade	Remarks
1	Case	2	Thermoplastic		Black
2	Actuator	2	Thermoplastic		Black
3	Equalizing lever	1	Stainless steel		

Company: Huizhou GATERON Electronic Technology Co., Ltd.

Address: No. 1, Songbei Road, China - Korea (Huizhou) Industrial Park, Zhongkai High Tech Zone, Huizhou City, Guangdong Province, China, 516000

Web: www.gateron.com

1

2

3

4

5

ITEM	Part Name	Material
①	Actuator	Thermoplastic(Black)
②	Case	Thermoplastic(Black)
③	Equaling lever	Stainless steel

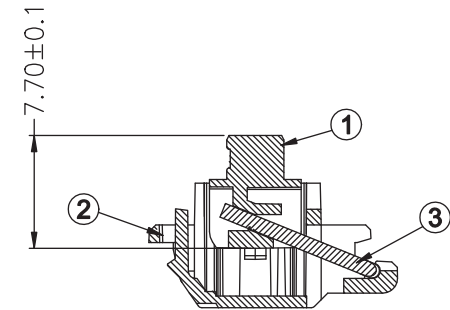
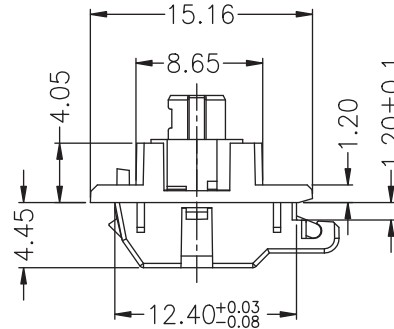
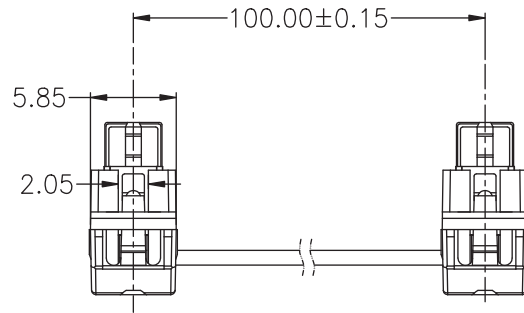
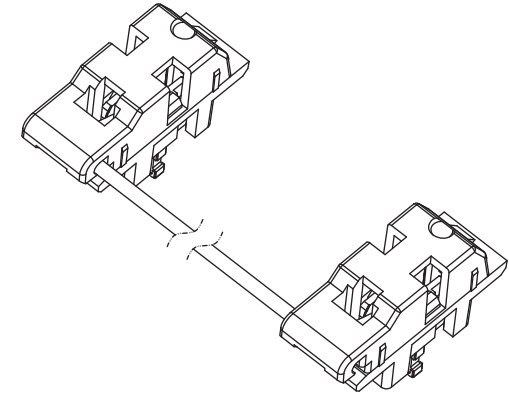
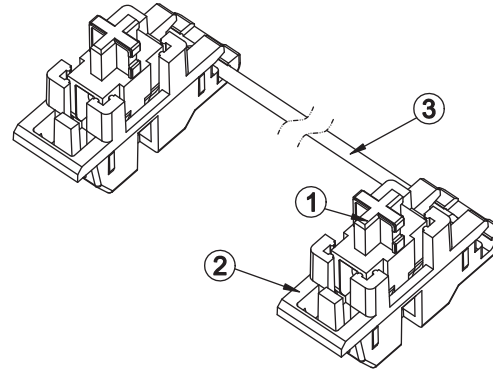
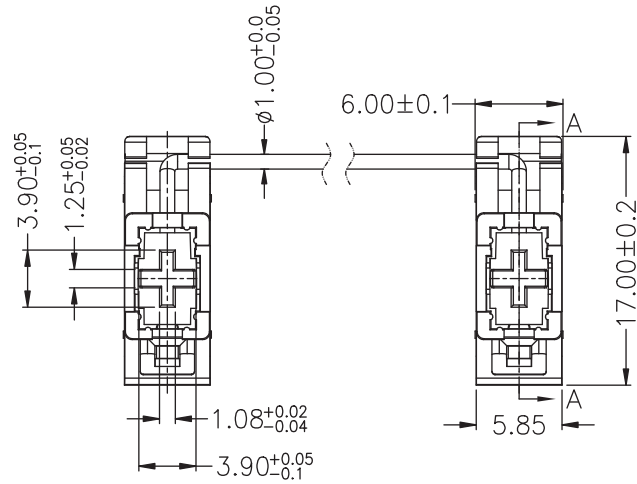

SECTION A-A

Title/Proj	KS-57 6.25X Holder Module			Tolerance Unless Otherwise Specified						
Part No	KS-57B623T	Version	3	~3	>3~10	>10~30	>30~80	>80~180	Angle	
Drawing No	KS-57B623T	Scale	2:1	±0.2	±0.3	±0.4	±0.6	±0.8	±3'	
Drafted by	Deng Yuqin	Date	2023-02-06	Unit: mm		Size: A4		SHEET 1 OF 1		
Checked by	Wu Furong	Date	2023-02-06	THIRD ANGLE		 GATERON <i>GATERON Electronic Technology Co.,Ltd</i>				
Approved by	He Shiyong	Date	2023-02-06							

1

2

3

4

5

DS-02-001-A0